



SISTEMI DIGITALI MF MONOCROMATICI

d-Copia

5001MF, 6001MF

: Security and Efficiency



- SPEED
- QUALITY
- COLOUR TOUCHSCREEN
- ECO-FRIENDLY
- NETWORK
- SECURITY
- MOBILITY AND CLOUD
- DIRECT WI-FI

d-Copia 5001MF/6001MF are the new mono A3 multifunctional systems offering features that match the top of the range in their reference market.

Advanced hardware and software security measures are integral to these models so as to ensure maximum data protection when executing document management procedures in office environments involving file sharing and storage, also on cloud.

The excellent 1200 x 1200 dpi printing quality obtained for monochrome represents the pillar on which can be built the most suitable configurations to meet Customer demands, exploiting a very rich suite of options available.

d-Copia 5001MF/6001MF are the result of the most efficient technology applied to consumable materials, prolonging life times to 600,000 pages between maintenance intervals, benefiting from the dual advantage of lower operating costs and reduced environmental impact.



EFFECTIVE BASIC PRINT RESOLUTION 1,200 X 1,200 DPI, PAPER FORMAT RANGE FROM A6 TO SRA3

WIDE RANGE OF SCANNING, FINISHING AND PAPER DRAWER OPTIONS TO REACH A MAX CAPACITY OF 7,150 SHEETS.

HIGH PRODUCTION COLOUR SCANNING UP TO 220 IPM.

4 GB RAM, 8 GB SSD + 320 GB HDD FOR JOB SAVING AND STORAGE.

MAXIMUM DATA PROCESSING SECURITY PROVIDED AS STANDARD BASED ON ENCRYPTION AND MEMORY OVERWRITES IN ACCORDANCE WITH STANDARD ISO/IEC 15408 EAL2 .

IMPROVED PRODUCTIVITY AND REDUCED QUEUING TIMES DUE TO NEW PRESENCE DETECTOR SENSOR .

RELIABILITY AND LOW ENVIRONMENTAL IMPACT THROUGH USE OF ORIGINAL CONSUMABLES WITH LONG LIFETIMES.

d-Copia

5001MF, 6001MF



New 9" touchscreen



d-Copia 6000MF with DP-7110+PF-7110+PF-7120+DF-7110+BF-730+MT-730

SECURITY ALWAYS

In their standard configuration, d-Copia 5001MF and 6001MF come with some of the most advanced solutions for data protection and conservation, including "Common Criteria" certification based on ISO/IEC 15408 EAL2 standards, involving encryption of data stored in memory and its subsequent deletion through multiple overwriting.

The task of generating data encryption keys is the realm of the TPM (Trusted Platform Module) chip that conserves them in a reserved area of memory. Adoption of the SIEM (Security Information & Event Management) architecture means that the entire machine operation is constantly monitored so as to ensure swift detection of error conditions that could potentially compromise operating security. Firmware integrity checks are provided on both d-Copia 5001MF and 6001MF systems that are activated on both system power on (Secure Boot) and when operating (Run Time).

Compliance with the standard and IEEE 2600.1 results in implementation of protection measures that apply to the whole system in its entirety in relation to password management policies.

RECORD LEVEL EFFICIENCY

The new d-Copia 5001MF and 6001MF come with a vast range of options including the new single pass DP-7130 originals feeder with a scanning capacity of up to 220 images per minute and an ultrasonic sensor able to detect the presence of double sheet feeds.

The new DF-7130 Finisher has a total capacity of 4200 sheets, with a stapling capacity of up to 100 A4 sheets or 50 A3 sheets from 3 different positions. Integrating with the BF-9100 folding and saddle stitching unit 80-page booklets and tri-folded brochures can be produced.

TECHNOLOGY AT TOP-OF-THE-RANGE

d-Copia 5001MF and 6001MF result from a sophisticated technology able to support a vast range of paper formats from A6 to SRA3 and with weights spanning from 52 to 300 g/m² for simplex and 64 to 256 g/m² for duplex printing.

Additionally, from drawer 1, envelopes in formats DL and C5 can also be fed in directly.

d-Copia 5001MF and 6001MF adopt technological solutions conceived expressly to enhance reliability,

increase quality and reduce power consumption.

To obtain these results, the QorIQ T1024 Dual Core processor has been adopted that, coupled with a new ASIC unit, permits an efficiency increase of 20%, with tangible benefits particularly when printing PDF format files. The 8 GB SSD memory is dedicated exclusively to the Operating System leaving the 320 GB Hard Disk free exclusively for user data.

The new 10.1" operator touchscreen is intuitive and simple to use.

CONFIGURATION LAYOUT

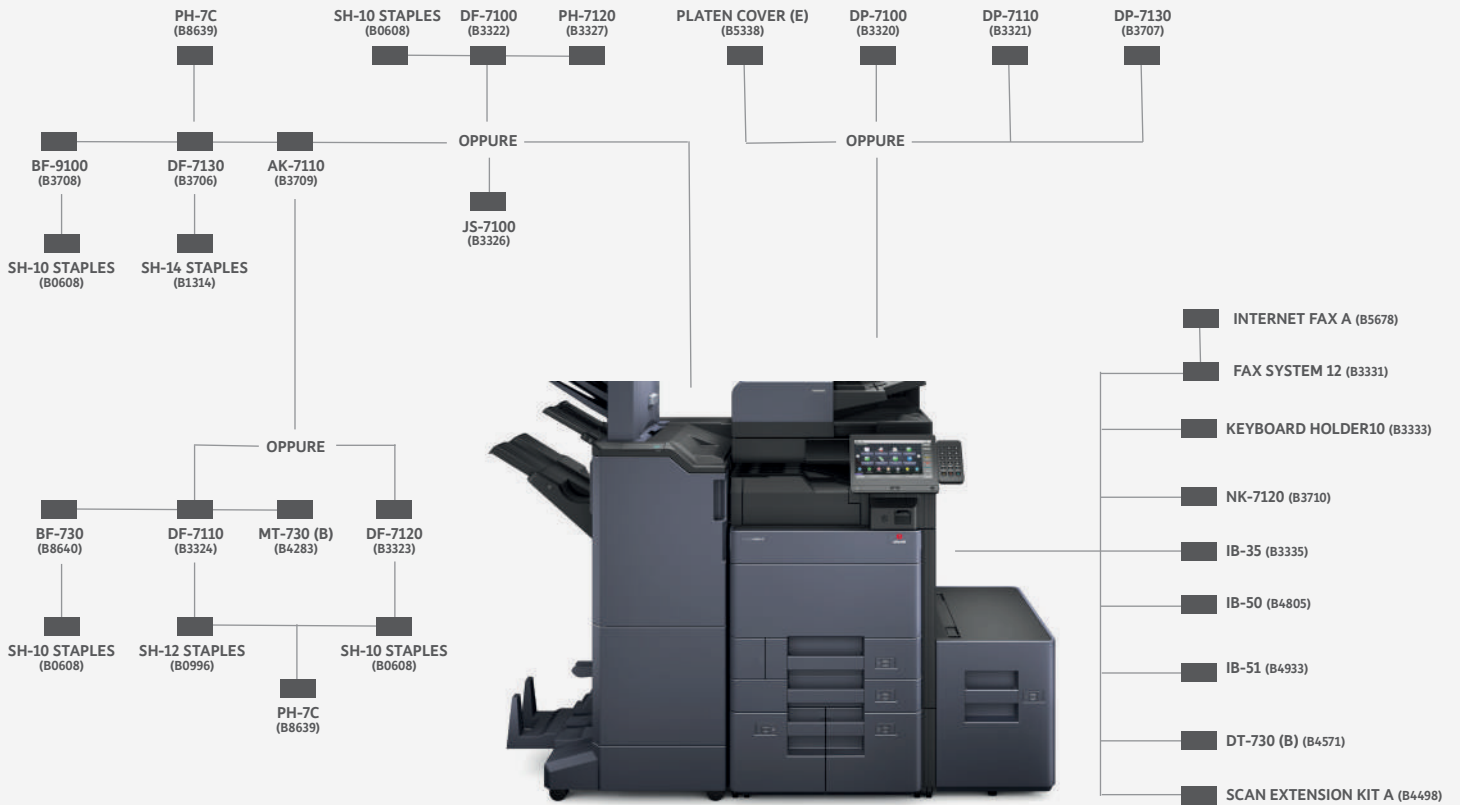

d-Copia 6001MF (B3705) d-Copia 5001MF (B3704)

- USB CARD READER Mifare/Multi ISO/Multi125 (B3689)
- USB CARD READER HID Prox/Indy Tag (B3690)
- USB CARD READER iClass (B3691)
- USB CARD READER LEGIC (B3692)

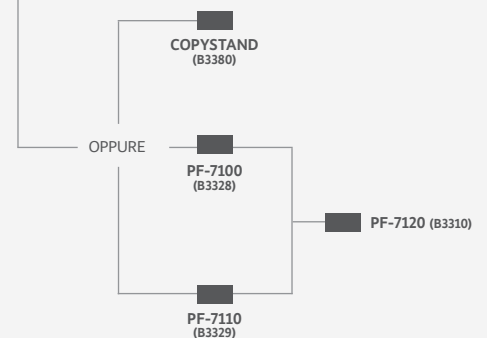

TECHNICAL SPECIFICATIONS

GENERAL

Type: Multifunctional Floorstanding Printer/Scanner/Copier

Technology: Monochrome laser with JAWS development platform for system customisation
Control panel dimensions: 256.5 mm (10.1") colour touchscreen, job notification speakers, adjustable tilt 15° - 90°

Power on warm-up time: 17 seconds approx or less

Input paper capacity: Universal 150-sheet bypass, 52 - 300 g/m² (Banner 136 - 163 g/m²), A6R - SRA3 (320 x 450 mm), custom (98x148 - 297x457.2); Banner max. 304.8 x 1,220 mm; standard universal paper drawers 2 x 500 sheet; 1st drawer A6R - A4R, 2nd drawer A6R-SRA3

Maximum paper capacity with options: 7,150 A4 sheets

Standard print modes, front/back: formats supported A6R - SRA3, 64 - 256 g/m²

Output paper capacity: Standard 500 sheets face-down, maximum 4,300 sheets with options (All paper capacities indicated relate to sheets having max thickness 0.11 mm).

Processor: Freescale QorIQ T1024 (Dual Core) 1.2 GHz

Memory (standard/max.): RAM 4 GB + SSD 8 GB + HDD 320 GB

Duty cycle (max. pages/month): 35,000

Standard interfaces: USB 3.0 (USB super speed) standard interface; 4 x USB Host interfaces, Gigabit Ethernet (10 BaseT/100 BaseTX/1000 BaseT, IPv6, IPv4, IPSec, 802.3az support), optional Wi-Fi (IEEE 802.11b/g/n), 2 x eKUIO slots for optional internal print server or optional Fax System, optional Wireless network slot, optional SD card slot, NFC Tag

Dimensions (W x D x H): Base unit 602 x 665 x 790 mm

Weight: Base unit 83 kg approx

Power consumption: AC 220 V ~ 240 V, 50/60 Hz

Power consumption printing/copying:

d-COPIA 5001MF: 740 W

d-COPIA 6001MF: 870 W

Ready/Standby modes: 50 W

Sleep mode: 0.7W

Print/copy noise levels (Noise emission level ISO 7779, ISO/IEC 24734, ISO 9296):

d-COPIA 5001MF: 70.5 dB (A) LWAd

d-COPIA 6001MF: 72.3 dB (A) LWAd

User access/accounting: up to 100/1000

Security: Encryption of data stored in machine memories (HDD) and its deletion according to ISO/IEC 15408 EOL2 standard (Common Criteria)
Security standards: GS, TÜV, CE

COPY FUNCTIONS

Copy speed

d-Copia 6001MF: Up to 60/30ppm A4/A3

d-Copia 5001MF: Up to 50/25ppm A4/A3

First copy out time:

d-Copia 6001MF: 3.4 secs approx

d-Copia 5001MF: 3.7 secs approx

Originals max format: A3

Continuous copying: 1 - 9999

Zoom: 25 - 400% in steps of 1%

Preset enlargement/reduction ratio: 5R/5I

Scan modes: Automatic, manual: 16 steps

Image adjustment: Text + photo, text, photo, diagram/map

PRINT FUNCTIONS

Print speeds (simplex/duplex)

d-Copia 6001MF: Up to 60 A4 ppm / 30 A3 ppm

d-Copia 5001MF: Up to 50 A4 ppm / 25 A3 ppm

First page out print time:

d-Copia 6001MF: 4.3 secs approx

d-Copia 5001MF: 3.8 secs approx

Print resolution: 1200 x 1200 dpi, 2-bit depth giving a print quality equivalent to 4800 x 1200 dpi, 600 x 600 dpi (scanning/copying)

Emulations: PCL 6 (PCL5c/PCL-XL), KPDL 3 (PostScript 3-compatible), PDF Direct Print, XPS Direct Print and Open XPS

Operating Systems: All current Windows operating systems, Mac OS X Version 10.9 or later, UNIX, LINUX;

Fonts/Barcodes: 93 scalable fonts (PCL), 136 fonts (KPDL3), 8 fonts (Windows Vista), 1 Bitmap font, 45 one-dimensional barcode types plus a two-dimensional barcode (PDF-417)

Mobile printing support: App Mobile Print for iOS and Android, AirPrint, NFC, Direct Wi-Fi

SCAN FUNCTIONS

Functionality: Scan to email, Scan to FTP, Scan to SMB, Scan to USB Host, Scan to Box, network TWAIN, WIA/WSD scanning

Scan speed, simplex

(DP-7100 A4, 300 dpi, mono & colour) 80 ipm

(DP-7100 A4, 600 dpi, mono & colour) 60 ipm

(DP-7100 A4, 300 dpi, mono & colour) 100 ipm

(DP-7100 A4, 600 dpi, mono & colour) 60 ipm

(DP-7130 A4, 300 dpi, mono & colour) 120 ipm

(DP-7130 A4, 600 dpi) 75 ipm mono & 70 ipm colour

Scan speed, duplex

(DP-7100 A4, 300 dpi, mono & colour) 48 ipm

(DP-7100 A4, 600 dpi, mono & colour) 36 ipm

(DP-7110 A4, 300 dpi, mono & colour) 180 ipm

(DP-7130 A4, 300 dpi, mono & colour) 220 ipm

Scan resolution: 600 dpi x 600 dpi, 400 dpi x 400 dpi, 300 dpi x 300 dpi, 200 dpi x 400 dpi, 200 dpi x 200 dpi, 200 dpi x 100 dpi, 256 grey shades for colour

Scan max format: A3, Ledger

Originals recognised: Text, photo, text + photo, light text/fine lines, OCR-optimised

File types: TIFF, PDF, PDF/A, JPEG, Open XPS, encrypted PDF, high compression PDF, PDF/A-1a/b, PDF/A-2a/b/u, searchable PDF (optional), MS Office files (optional)

FAX FUNCTION (OPTIONAL FAX SYSTEM 12)

Compatibility: ITU-T Super G3

Modem speed: 33.6 kbps max.

Transmission speed: 3 secs (JBIG) max.

Scan speed: 2 secs or less

Address book: 2000 entries

Originals max format: A3, Banner up to 1,600 mm

Compression modes: JBIG, MMR, MR, MH

CONSUMABLES

d-Copia 4000/5000/6000/5001/6001MF Toner

Yield up to 35,000 pages (36,500 pages ISO 19752).

Toner yield relates to pages in A4 format with 6% coverage and continuous printing mode.

WT-8500 Toner waste tray:

40,000 pages (based on 6% coverage)

Staple cartridges: SH-10 for DF-7100/DF-7120/BF-730, SH-12 for DF-7110, SH-14 for DF-7130

OPTIONS

Fax System 12

Internet Fax Kit (A)

Scan Extension Kit (A): Solution for scanning searchable PDFs (integrated OCR) with conversion to PDF or MS Office formats (docx, xlsx, pptx) Paper management

DP-7100 Originals automatic feeder: (with reversing), 140 sheets, 35 - 160 g/m² (front only), 50 - 120 g/m² (front-back), A6R - A3, Banner up to 1,900 mm

DP-7110 Originals automatic feeder: (single pass front-back scanning) 270 sheets, 50 - 80 g/m², 35 - 220 g/m² (front only), 50 - 220 g/m² (front-back), A6R - A3, Banner up to 1,900 mm

DP-7130 Originals automatic feeder: Same features as for DP-7110 but in addition ultrasonic sensor for detecting double sheet feeds

DT-730(B) Document tray

PF-7100 Paper drawers: 2x 500 sheets, 52 - 300 g/m², A6R - SRA3

PF-7110 Paper drawers: 2x 1,500 sheets, 52 - 300 g/m², A4, B5, letter

PF-7120 A4 Side drawer: 3,000 sheets, 60 - 300 g/m², A4, B5

DF-7100 Integrated Finisher: Main tray max. 500 A4 sheets; 52 - 300 g/m²; A6R- SRA3, stapling up to 50 A4 sheets or 30 A3 sheets in 3 positions

DF-7110 Document Finisher + AK-7110: Main tray: Max. 4,000 A4 sheets; Second-ry tray: 200 A4 sheets; 52 - 300 g/m²; max. A6R - SRA3. Stapling up to 65 A4 sheets or 30 A3 sheets in 3 positions, B5 - SRA3

DF-7120 Document Finisher + AK-7110: Main tray: 1,000 A4 sheets, 52 - 300 g/m², A6R-SRA3, stapling up to 50 A4 sheets or 30 sheets A3 in 3 positions

DF-7130 Document Finisher + AK-7110: Same features as DF-7110 with stapling for up to 100 A4 sheets or 50 A3 sheets in 3 positions.

PH-7C/PH-7D Punching Unit for DF-7120/DF-7110/DF-7130: 2-hole/4-hole/Swedish type, 60 - 256 g/m², A5R - A3

MT-730(B) DF-7110 Mailbox Sorter: 7 compartments x 100 A4 sheets, 50 A3/B4 sheets, 60 - 163 g/m²

BF-730 DF-7110 Brochure and tri-folding unit: Bi-folding: 52 - 256 g/m², A3, B4, A4R
Brochure: Max 16 sheets (64 pages, 60 - 90 g/m²); Folding without stapling: Max. 5 sheets (60 - 90 g/m²); Tri-folding: 60 - 105 g/m², A4R;
Multiple tri-folding: 5 sheets (60 - 90 g/m²), 3 sheets (91 - 105 g/m²)

BF-9100 DF-7130 Brochure and tri-folding unit: Bi-folding: 52 - 256 g/m², A3, B4, A4R
Brochure: Max. 20 sheets (80 pages, 60 - 90 g/m²) or max 13 sheets (52 pages, 91 - 105 g/m²)

Folding without stapling: Max 5 sheets (60 - 90 g/m²) or max 3 sheets (91 - 105 g/m²)

Tri-folding: 5 sheets (60 - 90 g/m²) or max 3 sheets (91 - 105 g/m²)

JS-7100 Job Separator: Internal 100-sheet job separator, 52 - 300 g/m², A5R - SRA3

PH-7120/PH-7130: Internal punching unit for DF-7100 internal Finisher, 2-4 holes/ Swedish type
Banner Guide 10: Feeder guide for banner format paper, 10 sheets

Keyboard 10 support

NK-7120 numeric keypad

USB IC Card Reader: Device licensed for various types of authentication; standard card port

UG-33: ThinPrint Support

UG-34: Emulations (IBM Proprinter/EPSON LQ-850/Diablo 630)

Optional interfaces

IB-35: Direct Wi-Fi interface

IB-50: Additional Gigabit-Ethernet 10 BaseT/100 BaseTX/1000 BaseT card

IB-51: Wireless network interface (802.11b/g/n) Platen type (E)

Copystand: Auxiliary metal stand

This product has been produced by a company operating in conformance with the ISO 9001 quality standard and ISO 14001 environmental directives.